

Study of In-Country Procedure of TCTPs/Initiatives under JARCOM: Cambodia

A- Background of the issues in the study

1. JARCOM is a regional cooperation in ASEAN region aiming at the transfer of the knowledge and technology among the ASEAN members under the support and coordination made by Japan through JICA. The important mission of this regional cooperation is to rectify the social and economic gaps among ASEAN members. From the perspective of the donor countries and as well as the previous concepts applied in international cooperation, such kind of mechanism is considered as the one in the type of “south-south” cooperation. The name JARCOM, which is the abbreviation of JICA-ASEAN Regional Cooperation Meeting, was given to the cooperation at the 3rd regional meeting held in Cambodia in July 2004. Historically, the first Meeting to Promote Regional Cooperation through JICA’s Programme among ASEAN Members was held in Kular Lumpur (15-18 July 2002) at the merge of the two separate regional meetings of the TCTP of the “senior” ASEAN countries and of the CLMV Regional Cooperation. At that time there was yet the mechanism¹ to support the cooperation. As the result, the resource member countries were requested to express at the meeting their capacities and the CLMV to express their needs. At the second Meeting to Promote Regional Cooperation through JICA’s Programme among ASEAN Members held in Vientian, Lao P.D.R. (October 2003) the CLMV has agreed commonly on the twelve agendas of regional cooperation and the senior ASEAN countries has offered their schemes of TCTPs to the needs identified under those agendas through the matching exercises of the bilateral meetings. One of the important agendas of the third Regional Meeting (JARCOM) was to find the way to improve the mechanism of the current cooperation. Many issues were identified as the problems to the current mechanism at that time including the lack of the unified formats for the management and facilitation of the information about the needs of CLMV, the late cooperation made by some members and the discussion on the applicability of the current common agendas of the CLMV. In the fourth meeting held in Hanoi (April 2005) those issues were discussed in the context of the follow-up of the action plans adopted in the third JARCOM. In addition, the discussion focused mainly on the improvement of the mechanism and future direction of JARCOM.
2. The discussion on the procedure and process of JARCOM management and coordination in each country of the JARCOM members was one of the main topics of the meeting of the virtual national staff network². The national staffs of

¹ JICA Thailand then was assigned to make the proposal on a new mechanism and that mechanism was agreed to follow by the members of the cooperation till the next meeting.

² The national staff virtual network of JARCOM was held at the 4th JARCOM at Hanoi, Vietnam. More detail about the meeting please see the draft summary of the meeting prepared jointly by the national staffs of JICA Thailand and Malaysia.

JICA office from each country of ASEAN members of JARCOM were requested to present and share information on the in-country procedures. During the discussion of the presentations, many problems inherent with the in-country process were identified particularly the ones with the official channel. The challenge at that time was to understand clearly the procedures in each county involved and to integrate those understandings in order to find out the effective way for the JARCOM operating mechanism for the beneficiary countries and the resource countries.

B- Objectives of the study/paper

3. The objective of this report is to identify the in-country procedure of the Cambodia and the issues with it. The report will try to seek the suggestions to improve the current procedure also.

C- Methodology

4. Initially, the work of this paper is based on the flowchart drawn by CRDB/CDC discussed at the consecutive meetings between CDC and JICA Cambodia Office before the 4th JARCOM in Hanoi (see annex-1). However, due to the lack of the comprehensiveness of that chart, the authors³ have set up a series of fact-finding interviews with the potential domestic stakeholders on the situation of the process/procedure of domestic management and coordination of the initiatives under JARCOM framework. The interview focused on four main areas of the understanding about the TCTPs of the participating interviewees. There are: the understanding of the TCTPs under JARCOM, the perception of the domestic stakeholders on the in-country process of TCTPs under JARCOM, the perceived roles and participation and their comments on the current process based on their experience of the process and participation (annex -2: questionnaire). From the information of these four pillars, the current flowchart of the in-country procedure of the TCTP management and facilitation of JARCOM in Cambodia is drawn.
5. For the line ministries/agencies, the interviewees were selected from the list of the ministries/agencies, which used to participate the TCTPs under JARCOM in the year 2004. The departments, which expected to deal importantly with the training affairs including the TCTPs under JARCOM, were selected for the interviews. As the result, heads of the departments of Personnel and/or Administration, or Training and/or Human Resource Development of the ministries/agencies were engaged for the information (please see the annex-3 for the detail information about the interviewees).
6. The pre-designed questionnaire for the interviews was used. However, the backup questions were made based on the actual situation of the interviewees.

³ The survey and report made by the JICA Cambodia Office by Mr. Nhean Tola and Mr. Peong Vattana, National Staffs, working respectively at the Planning section and Training section.

D-Findings of the interviews

7. Domestic stakeholders involved in Cambodia
 - a. Followings are the potential domestic stakeholders

Box 1: Domestic stakeholders and their roles under JARCOM

Council for the Development of Cambodia (CDC) is the national focal point of the JARCOM. In particular, CDC involves in the formulation stage of the TCTPs/initiatives under JARCOM. CDC participates the meeting of JARCOM every year since 2002 and was endorsed and perceived as the focal point of Cambodia under the framework. CDC conducts the ad-hoc inter-ministerial meetings complement (in some cases and on some occasions) by the need survey in order to identify the elaborated needs of Cambodia on TCTPs/initiatives under JARCOM. CDC uses the need identification form designed by itself to store and manage the needs of the line ministries/agencies. With JICA Cambodia Office, CDC consults and decides the prioritization of the needs before the list is submitted to JICA Thailand/JARCOM Secretariat for the matching exercises.

Ministry of Foreign Affairs and International Cooperation (MoFA &IC) is the official channel of information of the TCTPs. Usually, based on the practices so far, MoFA &IC of Cambodia is the entrance door of the TCTPs from the resource countries of JARCOM. In most cases, the notifications have been provided by the embassies of the resource countries as official documents to MoFA&IC. The TCTPs under JARCOM come through the same channel as the other trainings (ex. trainings under bilateral technical cooperation) from the embassies of the resource countries. Based on its mandate (Article 3-4) specified in the Anukret 77 on the Function of the Ministry, MoFA can serve as exit door of TCTPs information to the line ministries/agencies. At practice and in some cases, it jointly allocates the trainings of TCTPs of JARCOM with/without the information from the embassies. In summary, MoFA&IC's roles are to accept invitation from implementing institutions and to endorse the nominated participants in each TCTP in the implementing stage.

Line ministries/agencies are the main recipients of the TCTPs/initiatives under JARCOM. They are the main sources of the needs and the ultimate targets of the cooperation. At the formulation stage the line ministries/agencies identify their needs of the TCTPs, participate the inter-ministerial meetings invited and survey made by CDC and the fact-findings of the resource countries on the TCTPs or other initiatives of JARCOM.

JICA Cambodia Office mainly is the facilitator of the whole process. With the cooperation with other JICA offices in the region, JICA Cambodia Office cooperates to follow up the situation of the TCTPs in Cambodia at the formulation and the implementation stages. At the formulation process JICA Cambodia Office cooperate with CDC in prioritization of the elaborated needs and contact with the JARCOM secretariat for communicating the elaborated needs of Cambodia to the resource countries. Also, JICA Cambodia Office is the regular participant of the JARCOM regional meeting.

Embassies of resources countries in Cambodia: from the perspective of the domestic stakeholders the embassies should not be included. However, they are the initial place for information allocation of TCTPs under JARCOM. So far the embassies are the official channels that the resource countries use to provide the information on TCTPs and from these points the information has been sent officially to MoFA &IC.

Note: Embassy role is anticipated from the information provided by the line Ministries/agencies and CDC. The information relates to MoFA is based on the meeting held on 5th April 2005 between MoFA &IC, CDC and JICA Cambodia Office)

Source: the interview results.

b. Current in-country procedures

- The formulation process of the TCTP under JARCOM has been operated based on the inter-ministerial meeting and/or need survey made by CDC. According to the personnel involved in the JARCOM issues at CDC, the meeting and the survey are conducted in the ad-hoc way. The needs of the ministries or agencies are compiled and stored in the Need Identification Form designed by CDC (annex-4: blank form) Priority was given to those needs and some needs were identified as the national elaborated needs of Cambodia for the matching exercise at the regional meeting.
- The invitation processes implemented by the resource countries in Cambodia on the TCTPs vary from one resource country to another and based also on the practices of the official channel of resource countries in Cambodia (the embassies). The point here is the way that a resource country chooses to notify the beneficiary country. Usually, the embassies of the resource countries notify the MoFA&IC of Cambodia after they have got the information from the resource countries and the invitation was further allocated by the ministry to the domestic line ministries or agencies. However, according to the result of the interview some line ministries/agencies also got the official notification from the embassies. On the other hand, some just got the indirect information (carbon copy letter: cc) from the embassies at the same time the information was made to MoFA&IC. Figure-1 shows the different types of the invitation some line ministries and agency experienced with their coordination and management of TCTPs under JARCOM.

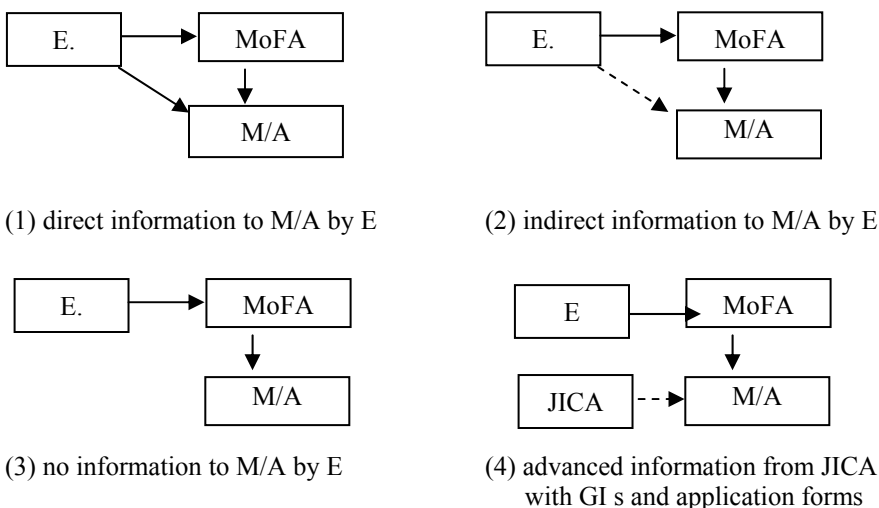

Note: E = embassies of resource countries	-----> = indirect information (cc)
M/A = line ministries or agencies	————> = direct/official information

Figure-1: Differences in the process of notification to the line ministries/agencies

According to the information provided by the officer at MIME, she got double official information in the same TCTP. One was provided by the MoFA&IC and another by the Embassy of Malaysia. According to the confirmation from MoFA officer in charge of the trainings of the Asia-I Department, usually the ministry will not invite the line ministries/agencies if it receives only the carbon copy letter (indirect notification) from the embassies. So it is likely that some embassies officially notify both MoFA and the line ministries/agencies. Anyway, the finding does not elaborate that this is the common case and only a case was found like that at the MIME. However, in the case of MoWRAM, SSCA and MPWT only the indirect notification was provided by the embassies of the resource countries. The Ministry of Interior (MoI) and the Ministry of Environment (MoE) got only information from MoFA &IC. In particular, the officers at the MoH informed that though she got the official invitation from the MoFA&IC, the information was addressed to her by JICA Cambodia Office in advance. She also elaborated that in most cases she got the GIs and the application forms from JICA Cambodia Office.

According to the information from the interviewees, MoFA &IC provided to the line ministries/agencies with its official invitation letter, the GI and application form (s) of each TCTP. However in some cases the line ministries/agencies need to seek such kinds of information from the other source that is not MoFA &IC or directly the information from the embassies.

- Selection and nomination process

Usually after the line ministries and agencies select and nominate the potential candidates they will send their official notifications to MoFA &IC for endorsement. Then, MoFA &IC will send the information to the corresponding embassies through its official channel of cooperation and in some cases when it gets the feedback from the embassies on the acceptance it informs the line ministries/agencies. However, many line ministries agencies involved in the interview informed that they needed to follow up the information by themselves sometime from the MoFA &IC and/or the embassies.

In the case that the line ministries/agencies received double official notifications from both MoFA and the embassies they needed to make two official notifications of their nominations to these two institutions. As the result, those line ministries/agencies worried about the unnecessary administrative work for the same course of TCTP of JARCOM.

Figure-2 summarizes all the aforementioned practices of the selection and nomination process.

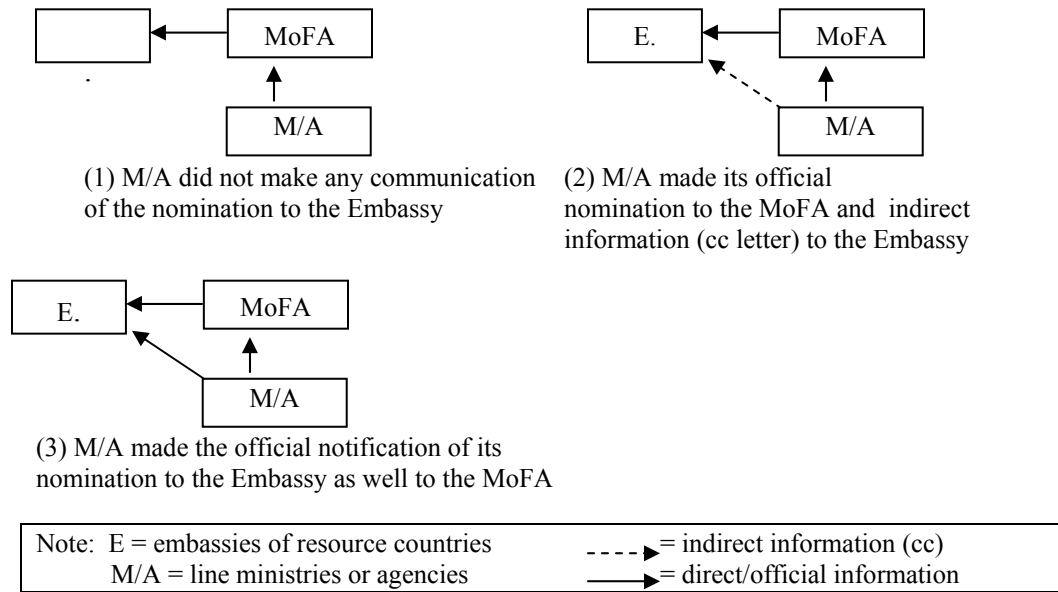
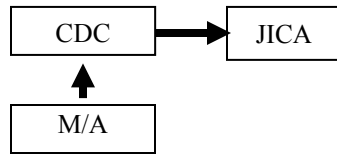
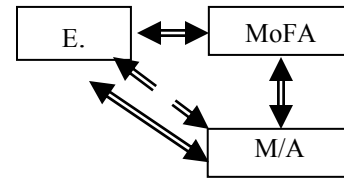

Figure-2: Information flow of nomination and its endorsement

- In summary the current in-country procedure of TCTPs under JARCOM can be illustrated in the figure-3 below. In that figure the procedure is divided into two steps—the formulation step and the implementation step (including the invitation and endorsement of nomination from the line ministries/agencies). There are two important notices from this process. First, it is the communication and information exchange made between CDC and the MoFA. As each step has been taken and is responsible by a different organization of the government, according to the interview result, the cooperation between the MoFA and CDC on the information sharing and consultation on the whole process of the TCTPs under JARCOM are rarely made. In recently there is the commitment from both organizations to exchange information with each other in the management and coordination of the TCTPs under JARCOM. Second, it is the way that the embassies notified the line ministries or agencies on the TCTPs under JARCOM. Usually the indirect information to the line ministries or agencies by the embassy in the invitation stage seems to be much more effective than the direct notification/invitation, if the embassies has already informed officially to MoFA & IC. However, the basis for the embassies to decide the line ministries or agencies they notify (direct or indirect) should be important also at this point.



(1) Formulation process



(2) Implementation process:
 Invitation from E to M/A and
 Nomination from M/A to E

Figure-3 current in-country process of the coordination and management of TCTPs in Cambodia

8. Other relevant issues of the procedures of JARCOM in Cambodia

a. Understanding of TCTPs under JARCOM

- i. Most ministries involved in the training courses did not understand the TCTPs under JARCOM and their differences from other types of the trainings the ministries received. They facilitated the total trainings including TCTPs of JARCOM based on the routine work by getting the information from the MoFA. The important notice is that the departments selected for the interview did not know about JARCOM and its national focal points (CDC). More surprisingly but likely the fact, is that knowledge of the department on the participation of the CDC-conducted inter-ministerial meeting and/or survey is very low. Many of them are not familiar with the need identification form of CDC and referred to it as the first time for them to see or hear when they were asked about it.

b. The in-country procedure of JARCOM

- i. Most of the interviewees knew MoFA & IC as the main provider of the information of the training courses they facilitated and managed including the TCTPs of JARCOM also. However, different ways of information communication made by the embassies of the resources countries confused the concepts of the cooperation of the line ministries and agencies. MIME and MoH mainly voiced their concern about this. MoE voiced its concern on the possibility of the uncoordinated information of TCTPs under JARCOM engaged by the departments, which are not involved in the planning of the trainings of the ministry.
- ii. It is also important to note that different selection approaches are used by different line ministries/agencies due to the management styles and the capacities of the departments involving in the TCTPs under JARCOM. There are many methods of management and facilitation, which provide different results and impacts to the selection and nomination process of the ministries. For example, SSCA's practice is much open and participatory with the

consideration to the input for the proper candidates from many departments involved⁴, while the approaches used by other line ministries seem to be centralized decision. Some departments also took the mixed approach based on the situation of the trainings and their knowledge and capacity to identify the targeted candidates.

- iii. From the context of the information received by the line ministries/agencies, the practices are different among the embassies and among the TCTPs under JARCOM. In some cases embassies made direct information to the line ministries or agencies and in the other cases they made indirect information (cc) to the line ministries or agencies and in the remaining cases, they just send information to MoFA &IC. According to the observation on the TCTPs in practices under JARCOM, the embassies will make notification to the line ministries/agencies at the same time they notified MoFA when they could identify clearly what were the targeted line ministries by their knowledge or other information from the resource countries⁵. However, so far there is no confirmation from the resource countries that they informed the embassies about the targeted line ministries/agencies of Cambodia.
- iv. In some cases the information of the TCTPs (GI and application forms) were allocated to many targets which not used the central departments of the line ministries or agencies. Since for those cases the line ministries and agencies must make the official notifications, some interviewees raised their concerns on the uncoordinated information and unproductive system to the line ministries or agencies.
- v. Also some departments of the line ministries voiced their concern on the on-time information provided by MoFA &IC.

E- Conclusion and Recommendations on the In-country Procedure

9. Though the practices of notification and information about the nomination are diversified from the individual cases in the figure-1 and -2, the practices (2) of the invitation of the TCTPs and practice (2) of the nomination can be considered the better way of the process. There are reasons to supporting these. First, the cases provide a clear path of information in giving and receiving the feedback. For example, all resource countries' embassies just made cc to the line ministries/agencies when they made official invitation through the MoFA &IC. This cc information does not require the line ministries to reply officially to the

⁴ According to the information got from the interview, the Training Department of SSCA invited all the Departments of SSCA to contribute their ideas on the potential candidates. According to them, this approach is used for the purpose of fair and effective selection and nomination.

⁵ Some letters of embassies to MoFA &IC have the cc to line ministries. However, some are not. In those cases the embassies just only made the addressing to MoFA&IC.

embassies and as the result it saved cost and time for the line ministries in managing and coordinating the TCTPs. Moreover, this indirect notification according to the line ministries and agency under the interview helps the ministries' or agency's preparation a lot in the selection process and in giving the on-time information to the MoFA &IC. Second, compared with other ways such practice seems to be more reliable and sustainable in the context of friendly and effective cooperation. This practice was implemented in more cases of TCTP under JARCOM than the other practices and was considered convenient and effective by the line ministries and agencies.

10. Since MoFA &IC is the main channel for the official information to the line ministries/agencies in Cambodia, the practice cannot overpass this point. As MoFA &IC (or in some cases the embassy of a resource country) takes and/or tend to take the role of the allocation of the training course information of JARCOM, it is recommended to the resource countries to included in their GI s or the letter of notifications the line ministries/agencies of Cambodia which they have been evaluated as the potential candidates for their TCTPs or for other initiatives of JARCOM.
11. On the connection of the formulation stage and implementation stage, it cannot be denied on the lack of the exchange of the information made by CDC and MoFA &IC (direct or indirect information provision). To improve the effectiveness of the procedure by avoiding the delivery of GI s to unsuitable line ministries/agencies, the exchange of information and consultation between CDC and MoFA &IC must be established. The strengthen of the communication and information exchange between CDC and MoFA &IC in the current procedure should be considered as the reinforcement to the suggestion above on the attachment or mention of the line ministries/agencies of Cambodia because each of these government institutions knows well the information in the stage it is involving. So far CDC and MoFA &IC seem to support this suggestion⁶.
12. It's important to know that the effectiveness of the JARCOM result is not dependent only on the proper and effective mechanism but also the quality of the proposed needs and the nominations made by the line ministries/ agencies. Some issues in relation to the capacities of and approaches used by the line ministries and agency were founded through the interview as well as the lack of the

⁶ Currently after the 4th JARCOM, Malaysia practices direct invitations to CDC. The implementing agencies send directly the information to CDC. CDC views this as the most convenient process. However, the concern is whether there is the possibility (officially as refer to the Anukret of the creation and function of MoFA&IC and practically to the consent of other resource countries to channel directly the information to CDC) to use such kind of route for all resource countries. Therefore, a predictable and reliable procedure, which includes CDC and other stakeholders under JARCOM, is important since line ministries/agencies should not be confused at the domestic level by the varied implementations of the resource countries. Plus, the current practice of Malaysia is not yet applied in all cases since there are still some TCTPs were informed by MoFA&IC. On the other hand, in promotion of this first-best option the effect of it on information sharing among other domestic stakeholders should be reviewed also. At the consultation of this report, CDC personnel regarded the suggested flow as the second-best option.

understanding or the misconception of the JARCOM and its mechanism by those line ministries or agencies. Though the scope of this paper is limited on those points, both Cambodia and the resource countries should not forget the relationship of these two factors in managing and facilitating TCTPs/initiatives under JARCOM.

13. Advanced information such as the GI s and course lists from JICA offices in the host countries to JICA Cambodia office is strongly requested for the facilitation of the TCTPs under JARCOM in a more effective and proactive way. It does not need to be the official information in the in-country procedure but it's important for such exchange of the information between JICA offices and cooperation among the responsible staffs. With advanced information JICA Cambodia office can support more effectively the domestic national stakeholders. At the same time, JICA Cambodia office needs to communicate also the advanced information of the nomination it gets from the national stakeholders to JICA offices in host countries for the early information to the implementing agencies there because in some cases the diplomatic channel can be slowly in sending the information for some reasons.
14. Figure-4 represents the suggestion for the reliable procedure of the domestic management and facilitation of TCTPs/initiatives under JARCOM for Cambodia.

Figure-4: Suggested In-country Procedure of Cambodia for JARCOM

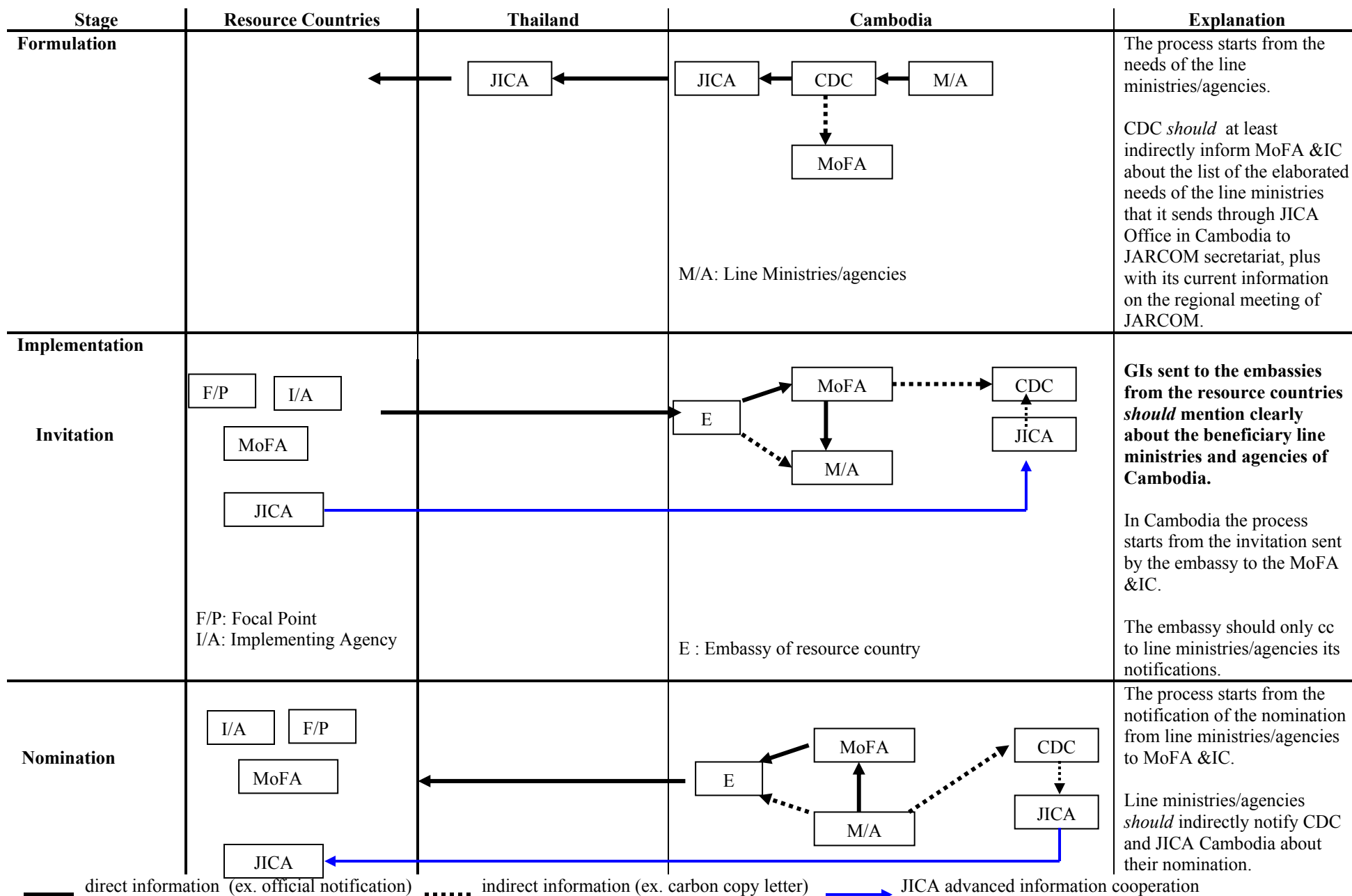

Source: derived from the result of the study and the discussions made with the stakeholders of the procedure.

Annex-1: JICA Third-Country Training Program (TCTP)-Malaysia's Case (by CDC/CRDB)

JICA Third-Country Training Program (TCTP) – Malaysia's Case

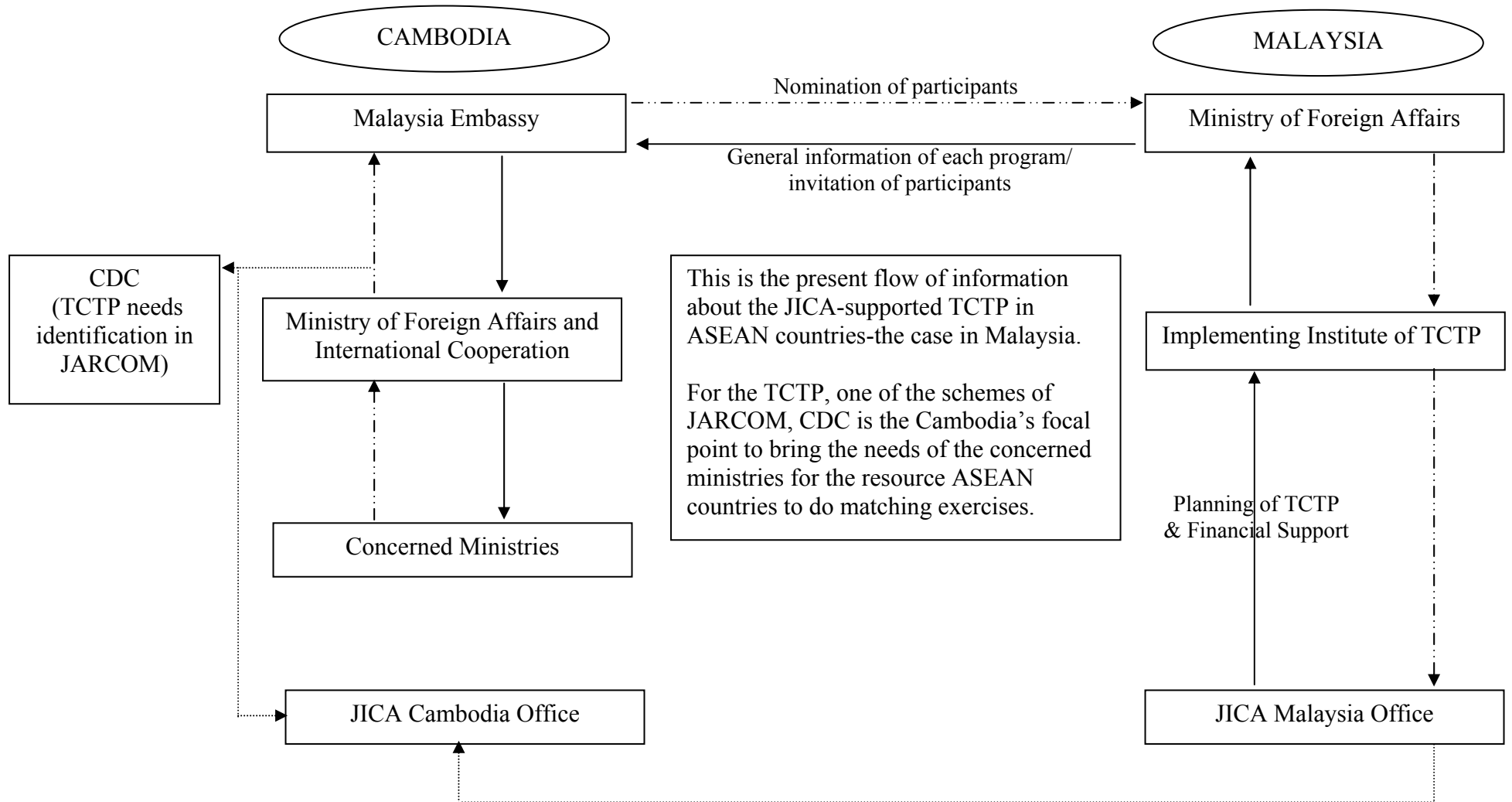

Annex 2: Questionnaire

1. Institutions recruiting TCTP Ex-participants:

- a. *<Understanding of TCTP>*
 - i. How much do you know about the benefits of the TCTP under JARCOM you used to handle and you are going to handle?
 - ii. From your point of view, how the TCTPs under JARCOM different from other trainings?
- b. *<Understanding of the in-country process of TCTP>*
 - i. How had you been notified about the TCTP under JARCOM?
 - ii. Who did you officially get the information about them?
 - iii. Had you been informed officially about “who” would provide you the official information? If so, who made such kind of information?
 - iv. What kinds of information did you receive? Was it GI?
 - v. Was the information clearly provided and you could work out the next steps? Did the information clearly explain the next steps you should take? Was it totally sufficient and clear enough for you? If not, what is your suggestion to make it clear and sufficient?
- c. *<Understanding the roles and participation>*
 - i. What had you been done after you got the information?
 - ii. Could you list the steps of your actions?
 - iii. Did you know which point of the process you should connect your actions to?
- d. *<Opinions about the feasible process>*
 - i. How do you think about the current process? Any difficulties?
 - ii. Do you have any suggestions to improve the current process?

2. MoFA (MoFA requested to use the discussion on 5th April 2005 between it, CDC, and JICA as the information for these questions)

- a. *<Understanding of TCTP>*
 - i. How many training schemes has MoFA facilitated and coordinated so far? Can you describe them? Have there been any TCTP?
 - ii. How different MoFA has perceived on TCTP and other training schemes? MoFA classification of the trainings and its facilitations?
 - iii. Do MoFA apply one fixed cooperation concept on those trainings or flexible according to the types and nature of cooperation, which require by the training?
- b. *<Understanding the in-country procedure of TCTP>*
 - i. After getting GI of a TCTP from the embassy of ASEAN countries what have MoFA done as its next steps?
 - ii. Have MoFA been informed that its domestic partner in cooperation is CDC?
 - iii. Have MoFA got any forward information from CDC about the updates of TCTP or about JARCOM at the stage of project formulation and identification?
 - iv. What has MoFA done before sending out TCTP GI to the targets? Any consultation with CDC? If no, why not?
- c. *<Understanding role and participation>*
 - i. How MoFA practically views itself in facilitating TCTP and JARCOM?
 - ii. What kind of importance MoFA attach to itself under this framework? Efficient information provider or efficient national distributor?
- d. *<Opinions about the feasible process>*
 - i. How MoFA think about the effectiveness of the current process?

- ii. Do MoFA have any suggestions for the improvement of the process?
- 3. **CDC:**
 - a. *<Understanding of TCTP>*
 - i. Are there other trainings required CDC to facilitate beside TCTPs of JARCOM?
 - ii. Describe briefly the process of TCTP you experience in coordination.
 - b. *<Understanding of role and participation>*
 - i. What role CDC plays so far under JARCOM?
 - ii. How CDC facilitates the identification and formulation of TCTP under JARCOM with domestic line ministries and with resource members of JARCOM?
 - iii. Has CDC notified MoFA about its activities under JARCOM? Any information exchange so far? If so which department at MoFA?
 - iv. Has CDC provided the explanation of the JARCOM, its tools and process to other domestic stakeholders such as line ministries and MoFA? How does CDC view this activity? Important in its role or not?
 - v. It seems that CDC changed a bit its mechanism in finding out the elaborated needs of Cambodia under JARCOM from inter-ministerial meeting to the on-spot survey, why CDC did so?
 - c. *<Opinions about the feasible process>*
 - i. How CDC thinks about the effectiveness of the current process?
 - ii. Does CDC have any suggestions for the improvement of the process?

Annex 3: List of the interviewees

Institution	Interviewees and Position
Council for Development of Cambodia/ Cambodia Rehabilitation and Development Board (CDC/CRDB)	Ms. Heng Sokun Director of Bilateral Aid Coordination Department Japan-Asia Pacific and America Ms. Harumi Okawa JICA Advisor at CDC
Ministry of Industry Mines and Energy (MIME)	Ms. Pich Channary Chief of Training Department
Ministry of Environment (MoE)	H.E. Dr. Lonh Heal Director General of Technical General Department Mr. Ma Chan Sethea Chief of International Relation & ASEAN Office
Ministry of Health (MoH)	Ms. Keat Phoung Director of Human Resource Development Department
Ministry of Interior (MoI)	Lt. Col. Chhun Chan Than Chief of Training Plan Office
Ministry of Water Resources and Meteorology (MoWRAM)	Mr. Sovann Vice-chief of Training Office
Ministry of Public Work and Transport (MPWT)	Mr. Meas Monika Director of Personnel Department
State Secretariat of Civil Aviation (SSCA)	Mr. Seng Vanny Director of the Personnel and Administrative Department

Annex 4: Need Identification Form (by CDC/CRDB)

Regional Training Needs Identification Form
Prepared by _____

Name of Priority Area			
Current Situation of the Sector in Cambodia and Problems of the Sector to be Solved			
Title of Project			
Modality	Training /Seminar/ Study Tour or Depend on the sources		
Contents (subjects to be discussed/learned, information to be shared, skills to be introduced, etc.)			
Length		Frequency	
Expected Results			
Qualification of Participants (person, responsibilities, academic/working experience, etc.)			
Total No. of Participants and Number of Cambodian Participants	_____ Cambodians out of total _____ participants		
Place			
Possible Learning Institution, if any			
Other Relevant Information (ex., Cambodian contribution, etc.			